



Standard & Slimline Countertop Holding Drawers

Standard Models: HDD-1 HDD-2 HDD-3 Slimline Models: HDDS-1 HDDS-2 HDDS-3

PRODUCT:

QUANTITY:

ITEM #:

Designed Smart

Developed for High Performance!

- The APW Wyott Holding Drawers are designed to hold all "potentially hazardous foods" at required NSF temperatures.
- Heating system is designed to provide fast start-ups, quickly heating to temperatures up to 200 degrees.
- Thermometer in control panel accurately reflects temperature in drawer area. Operators can achieve the optimal holding condition that keeps food safe but does not over-heat food products.

Maximum Versatility!

- Perimeter heating elements distribute heat evenly through the drawer area, allowing for maximum control of your temperature needs.
- Handles crispy or moist food equally well by using adjustable louvers on each drawer. This feature retains the ideal moisture level in the compartment.

Energy Efficient!

- Top and side panels are built with 1-inch fiberglass insulation pads.
- Insulation keeps heat in and keeps exterior panels "cool to the touch."

Easy to Maintain and Service!

- Removable pan allows for quick clean up of drawer area.
- Front mounted control panel is easy to access and service.

Built Solid

Built to Last

- Exterior is built with heavy-duty stainless steel to protect against kitchen wear and rust.
- Drawers are constructed with reinforced 14 gauge stainless steel drawer slides. (Will not bend or warp drawer tracking system.)
- 85% increase in drawer bracket support. Drawer Roller brackets re-inforced by two 16 gauge stainless steel plates.
- Drawers have built-on horizontal stainless steel handles.

Reliability backed by APW Wyott's Warranty

- All APW Wyott holding drawers are backed by a 1-year parts and labor warranty, including on-site service calls within 50 miles of authorized service technicians.
- Certified by the following agencies:



MODEL HDD-1 COUNTERTOP HOLDING DRAWER

APW Wyott Design Features

- Heavy-duty stainless steel with 1" fiberglass insulation.
- 14 gauge stainless steel drawer slides.
- Each drawer individually controlled by a protected thermostat, indicator lamp and rolling read-out thermometer.
- Temperature range of 100° - 200°F (38°C - 93°C).
- Adjustable louvers on each drawer.
- Each drawer has removable 12"x20"x6 1/2" deep stainless steel liner pan.

Options

- Perforated well-pan bottom
- Full and fractional size steamtable pans up to 6" deep

See reverse side for product specifications.



APW Wyott Foodservice Equipment Company · 729 Third Ave., Dallas, TX 75226
(800) 527-2100 · (214) 421-7366 · Fax (214) 565-0976 · www.apwwyott.com · info@apwwyott.com

Rev. 5/22/2005



Standard & Slimline Countertop Holding Drawers

Standard Models: HDD-1 HDD-2 HDD-3 Slimline Models: HDDS-1 HDDS-2 HDDS-3

PRODUCT: QUANTITY: ITEM #:

Standard Versions

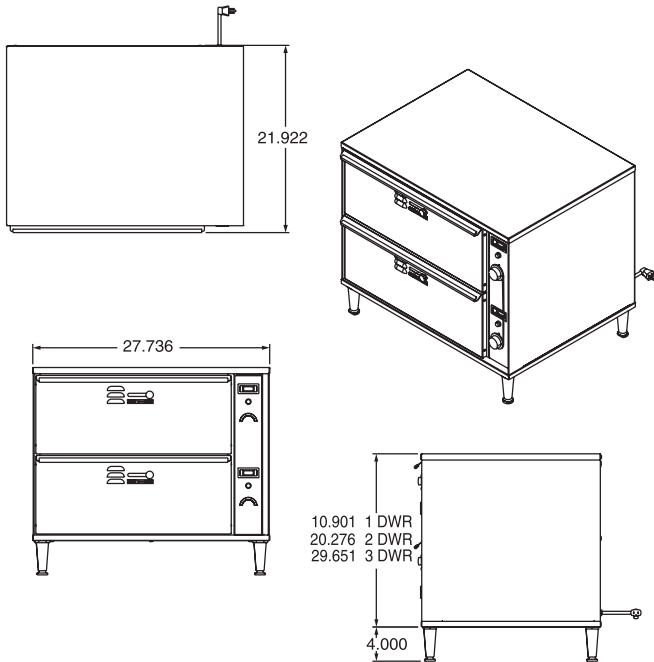

Slimline Versions

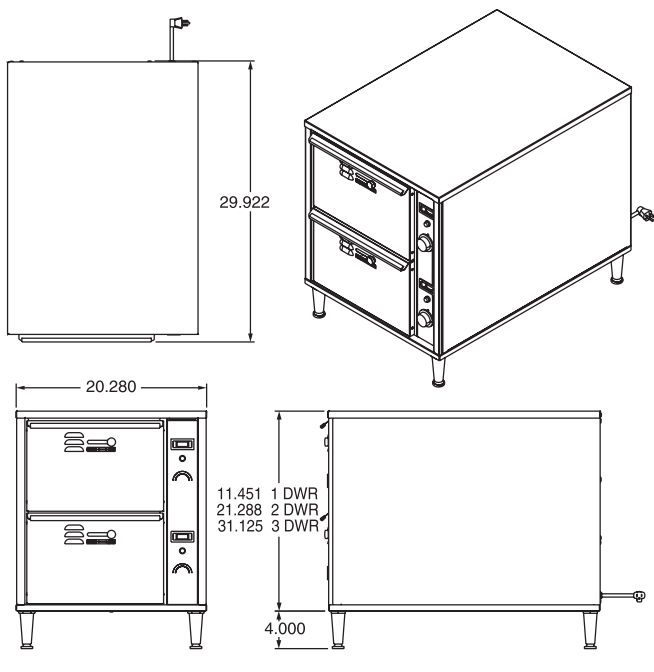

PRODUCT SPECIFICATIONS

Construction:

Stainless steel exterior construction; reinforced stainless steel drawer slides and roller; insulated on top and side panels with 1-inch fiberglass insulation.

Electrical Information:

Each unit is equipped with a 60", three wire grounded power cord that terminates with a 90 degree three-pronged male plug. The 120V unit uses a NEMA 5-15P plug. The 208/240V unit uses a NEMA 6-20P plug.

Shipping:

Freight Class: 92 1/2

FOB: Dallas, TX

Standard Holding Drawers

	Electric	Dimensions	Shipping Wt.
HDD-1	120V, 450W, 3.8 Amps	14 15/16" H x 27 3/4" W x 21" D (379 mm x 705 mm x 533 mm) *	84 lbs (38 kg)
	208V, 450W, 2.1 Amps		
	240V, 450W, 1.8 Amps		
HDD-2	120V, 900W, 7.5 Amps	24 5/16" H x 27 3/4" W x 21" D (618 mm x 705 mm x 533 mm) *	175 lbs (79 kg)
	208V, 900W, 4.3 Amps		
	240V, 900W, 3.7 Amps		
HDD-3	120V, 1350W, 11.3 Amps	33 11/16" H x 27 3/4" W x 21" D (856 mm x 705 mm x 533 mm) *	254 lbs (115 kg)
	208V, 1350W, 6.5 Amps		
	240V, 1350W, 5.6 Amps		

*Includes legs without handle.

Slimline Holding Drawers

	Electric	Dimensions	Shipping Wt.
HDDS-1	120V, 450W, 3.8 Amps	15 7/16" H x 20 1/4" W x 29 5/16" D (392 mm x 514 mm x 744 mm) *	84 lbs (38 kg)
	208V, 450W, 2.1 Amps		
	240V, 450W, 1.8 Amps		
HDDS-2	120V, 900W, 7.5 Amps	25 5/16" H x 20 1/4" W x 29 5/16" D (643 mm x 514 mm x 744 mm) *	175 lbs (79 kg)
	208V, 900W, 4.3 Amps		
	240V, 900W, 3.7 Amps		
HDDS-3	120V, 1350W, 11.3 Amps	35 1/8" H x 20 1/4" W x 29 5/16" D (892 mm x 514 mm x 744 mm) *	254 lbs (115 kg)
	208V, 1350W, 6.5 Amps		
	240V, 1350W, 5.6 Amps		

*Includes legs without handle.

*APW Wyott reserves the right to modify specifications or discontinue models without incurring obligation.



APW Wyott Foodservice Equipment Company · 729 Third Ave., Dallas, TX 75226
(800) 527-2100 · (214) 421-7366 · Fax (214) 565-0976 · www.apwwyott.com · info@apwwyott.com

Rev. 5/22/2005

1028