



Standard & Slimline Built-In Holding Drawers

Models: HDDS-1B HDDS-2B HDDS-3B HDDS-1B HDDS-2B HDDS-3B

PRODUCT:

QUANTITY:

ITEM #:

Designed Smart

Developed for High Performance!

- The APW Wyott Built-In Holding Drawers are designed to hold all "potentially hazardous foods" at required NSF temperatures.
- Heating system is designed to provide fast start-ups, quickly heating to temperatures up to 200 degrees.
- Thermometer in control panel accurately reflects temperature in drawer area. Operators can achieve the optimal holding condition that keeps food safe but does not over-heat food product.

Maximum Versatility!

- Perimeter heating elements distribute heat evenly through the drawer area, allowing for maximum control of your temperature needs.
- Handles Crispy or Moist food equally well by using adjustable louvers on each drawer. This feature retains the ideal moisture level in the compartment.
- Drawers can handle a variety of Pan insert sizes or be utilized directly without inserts, utilizing 12 x 20 x 6 1/2" pan liner provided.

Energy Efficient!

- Top and side panels are built with 1-inch fiberglass insulation pads.
- Insulation keeps heat in and keeps exterior panels "cool to the touch."

Easy to Maintain and Service!

- Removable pan allows for quick clean up of drawer area.
- Front mounted control panel is easy to access and service.

Built Solid

Built to Last

- Exterior is built with heavy-duty stainless steel to protect against kitchen wear and rust.
- Drawers are constructed with reinforced 14 gauge stainless steel drawer slides. Will not bend or warp drawer tracking system.
- 85% increase in drawer bracket support. Drawer Roller brackets re-inforced by two 16 gauge stainless steel plates.
- Drawers have built-on horizontal stainless steel handles.

Reliability backed by APW Wyott's Warranty

- All APW Wyott holding drawers are backed by a 1-year parts and labor warranty, including on-site service calls within 50 miles of authorized service technicians.
- Certified by the following agencies:



SANITATION



Built-In Holding Drawer

APW Wyott Design Features

- Heavy-duty stainless steel with 1" fiberglass insulation.
- 14 gauge stainless steel drawer slides.
- Each drawer individually controlled by a protected thermostat, indicator lamp and rolling read-out thermometer.
- Temperature range of 100° - 200°F (38°C - 93°C).
- Adjustable louvers on each drawer.
- Each drawer has removable 12"x20"x6 1/2" deep stainless steel liner pan.
- Built-Ins have a Terminal Block for quick installation.

Options

- Perforated well-pan bottom (14900)
- Full and fractional size steamtable pans up to 6" deep

See reverse side for product specifications.



APW Wyott Foodservice Equipment Company · 729 Third Ave., Dallas, TX 75226
(800) 527-2100 · (214) 421-7366 · Fax (214) 565-0976 · www.apwwyott.com · info@apwwyott.com

Rev. 5/22/2005



Standard & Slimline Built-In Holding Drawers

Models: HDDS-1B HDDS-2B HDDS-3B HDDS-1B HDDS-2B HDDS-3B

PRODUCT: QUANTITY: ITEM #:

Standard Built-In Drawers (HDD Models)

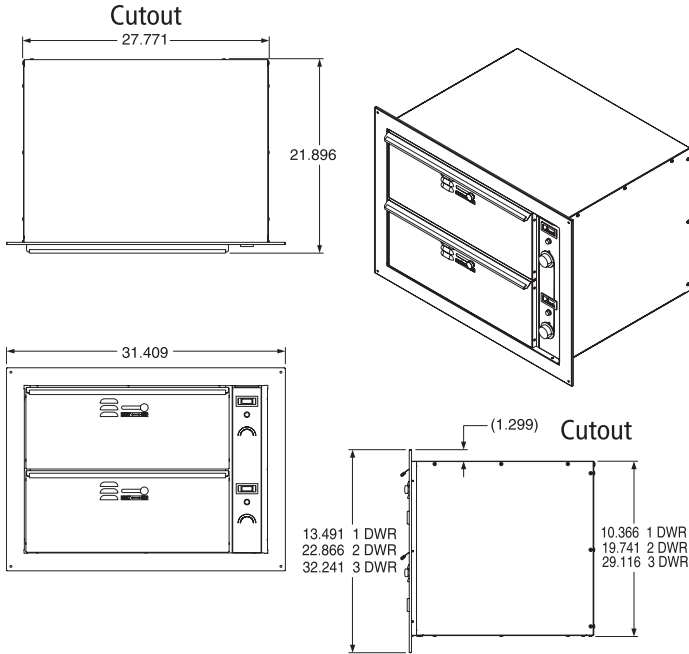

Slimline Built-In Drawers (HDDS Models)

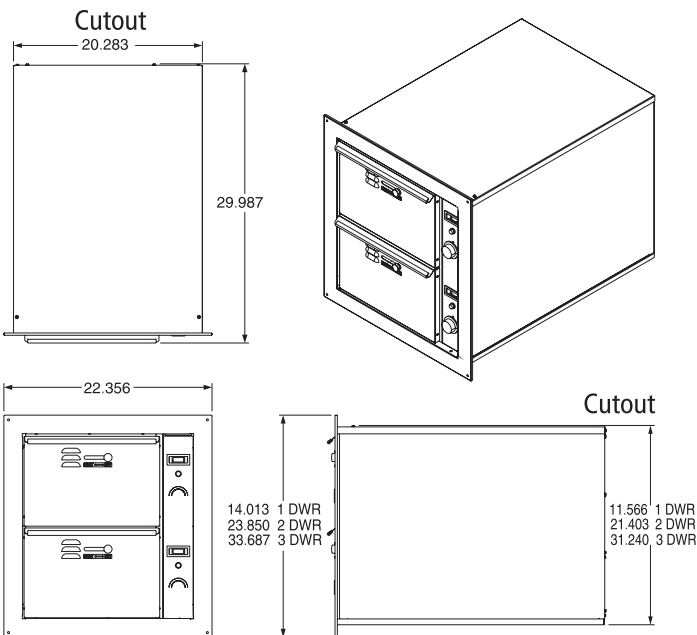

PRODUCT SPECIFICATIONS

Construction:

Stainless steel exterior construction; reinforced stainless steel drawer slides and roller; insulated on top and side panels with 1-inch fiberglass insulation.

Electrical Information:

Each unit is equipped with a terminal block that is ready for field wiring.

Flange Information:

	Top	Side
Standard:	1 5/16"	1 13/16"
Slimline:	1 1/8"	15/16"

Shipping:

Freight Class: 92 1/2

FOB: Dallas, TX

Standard Holding Drawers

	Electric		Dimensions	Shipping Wt.
HDD-1B	120V, 450W, 3.8 Amps	Base Unit	10 3/8" H x 27 3/4" W x 20 11/16" D (264 mm x 705 mm x 525 mm)	84 lbs. (38 kg)
	208V, 450W, 2.1 Amps 240V, 450W, 1.8 Amps		Cutout 10 3/4" H x 27 13/16" W (273 mm x 706 mm)	
HDD-2B	120V, 900W, 7.5 Amps	Base Unit	19 3/4" H x 27 3/4" W x 20 11/16" D (502 mm x 705 mm x 525 mm)	175 lbs. (79 kg)
	208V, 900W, 4.3 Amps 240V, 900W, 3.7 Amps		Cutout 20" H x 27 13/16" W (508 mm x 706 mm)	
HDD-3B	120V, 1350W, 11.3 Amps	Base Unit	29 1/8" H x 27 3/4" W x 20 11/16" D (740 mm x 705 mm x 525 mm)	254 lbs. (115 kg)
	208V, 1350W, 6.5 Amps 240V, 1350W, 5.6 Amps		Cutout 29 5/8" H x 27 13/16" W (752 mm x 706 mm)	

Slimline Holding Drawers

	Electric		Dimensions	Shipping Wt.
HDDS-1B	120V, 450W, 3.8 Amps	Base Unit	11 3/8" H x 20 15/16" W x 28 7/8" D (289 mm x 531 mm x 733 mm)	84 lbs. (38 kg)
	208V, 450W, 2.1 Amps 240V, 450W, 1.8 Amps		Cutout 11 3/4" H x 20 1/2" W (298 mm x 521 mm)	
HDDS-2B	120V, 900W, 7.5 Amps	Base Unit	21 1/4" H x 20 15/16" W x 28 7/8" D (545 mm x 531 mm x 733 mm)	175 lbs. (79 kg)
	208V, 900W, 4.3 Amps 240V, 900W, 3.7 Amps		Cutout 21 5/8" H x 20 1/2" W (549 mm x 521 mm)	
HDDS-3B	120V, 1350W, 11.3 Amps	Base Unit	31 1/8" H x 20 15/16" W x 28 7/8" D (794 mm x 531 mm x 733 mm)	254 lbs. (115 kg)
	208V, 1350W, 6.5 Amps 240V, 1350W, 5.6 Amps		Cutout 31 1/8" H x 20 1/2" W (790 mm x 521 mm)	

*APW Wyott reserves the right to modify specifications or discontinue models without incurring obligation.



APW Wyott Foodservice Equipment Company · 729 Third Ave., Dallas, TX 75226
(800) 527-2100 · (214) 421-7366 · Fax (214) 565-0976 · www.apwwyott.com · info@apwwyott.com

Rev. 5/22/2005

1028