



RACER™ Horizontal Open Air Merchandisers

PRODUCT:

QUANTITY:

ITEM #:

Models: DMXS, DMXD -30H, 36H, 42H, 48H, 54H, 60H

Designed Smart

New Racer™ Line of Horizontal Display Shelves!

- New, great looking display merchandiser that keeps a variety of packaged foods hot...and providing fast and easy accessibility for the consumer.
- Racer™ Merchandisers keep wrapped product at NSF safe temperatures through a system of infrared overhead heat and a thermostatically controlled heated base. The heated holding area is designed to have enough reserve power to overcome variations in temperature and air movement.
- All models have a constant level of infrared top heat directing a "curtain of heat" to the front edges of the holding surface where heat loss is the greatest.

Versatile Design and Options!

- Horizontal flat Racer™ Merchandisers are available in one or two shelf versions. Lengths are available from 24" of displayable area (DMX-30 styles) to 54" displayable area (DMX-60 styles).
- Powder coated front and side accents compliment your operation's décor. The Racer™ line comes standard with a Black front with red inset along with a red side panel. Available in a variety of other colors that are perfect for front of the house use.
- Inset panels for the front match side color panel and can be used for product identification signs or price markers.

Built Solid

Built to Last

- The Racer™ line is the most durable and sturdy merchandiser on the market...infrastructure and support is made of solid stainless steel. Unit will not sway from side to side or sag in the middle.
- Heated base is designed with special coated aluminum that transfers heat efficiently, plus allows boxes and wrapped products to smoothly slide down toward the front.
- Tempered glass end panels allow maximum visibility, while shatter resistant incandescent lights illuminate the merchandising area.

Reliability backed by APW Wyott's Warranty

- Certified by the following agencies:



RACER™ Horizontal Open Air Heated Merchandisers

APW Wyott Design Features

- Heavy Duty Stainless Steel construction for base, sides and tops
- Hard coated aluminum heat shelf
- 1½" Insulation throughout Shelf base
- Polished Mirror Stainless Steel reflectors on top heat
- Thermostatically controlled heat for base and rear overhead heat source
- Decorative powder coated sides, fronts, back and insets
- Shatter resistant incandescent lights
- 4" High Temperature Polycarbonate and steel legs
- Tempered glass sides for maximum visibility
- Pilot light

Options

- **Powder Coated Front and Back Shelf Extrusions**
 - Black is standard
 - White
 - Blue
 - Red
 - Green
- **Powder Coated Side Support**
 - Red is standard
 - White
 - Yellow
 - Black
- **Powder Coated Inset Panel**
 - Red is standard
 - White
 - Yellow
 - Black

- **Note:** Additional Custom Colors are available... Please contact the factory for details.

See reverse side for product specifications.



APW Wyott Foodservice Equipment Company · 729 Third Ave., Dallas, TX 75226
(800) 527-2100 · (214) 421-7366 · Fax (214) 565-0976 · www.apwwyott.com · info@apwwyott.com

Rev. 4/12/2004

PRODUCT:

QUANTITY:

ITEM #:

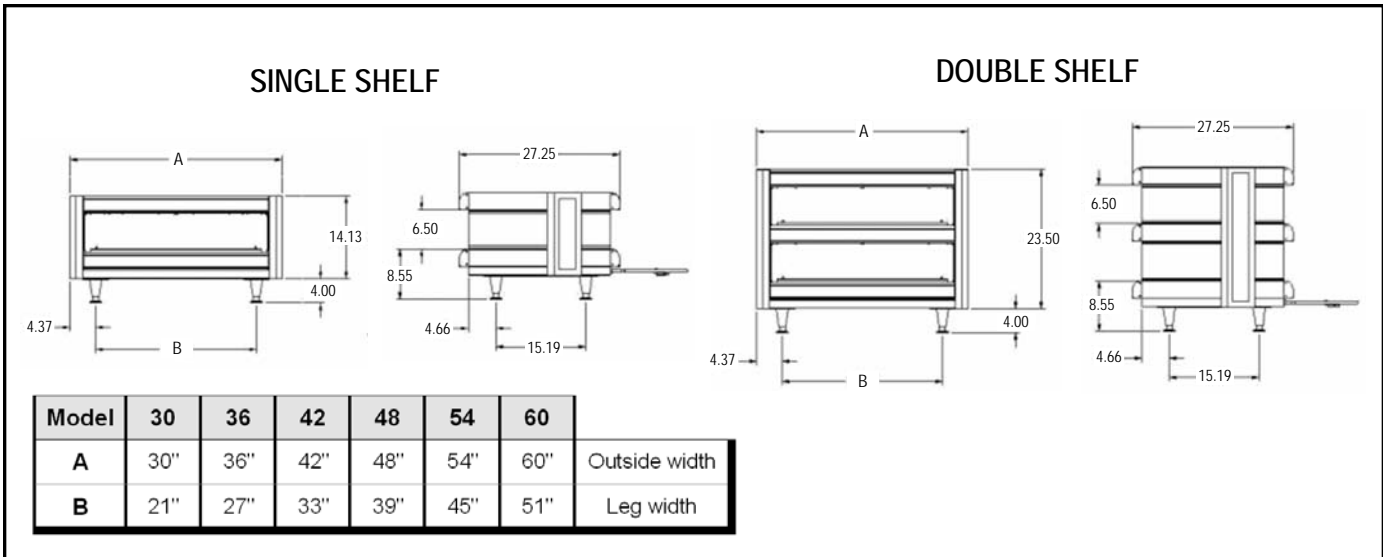

Racer™ Horizontal Display Merchandiser—Single Shelf

	Electrical	Dimensions	Ship Wt.	Divider Rods
DMXS-30H	120V, 695W, 5.75 Amps	18 1/8"Hx30"Wx27 1/4"D (46 x 76.2 x 69cm)	150 lbs (68.2 kg)	5
DMXS-36H	20V, 845W, 7 Amps	18 1/8"Hx36"Wx27 1/4"D (46 x 91.4 x 69cm)	161 lbs (73.2 kg)	6
DMXS-42H	120V, 995W, 8.2 Amps	18 1/8"Hx42"Wx27 1/4"D (46 x 106.6 x 69cm)	179 lbs (81.4 kg)	7
DMXS-48H	120V, 1240W, 10.3 Amps	18 1/8"Hx48"Wx27 1/4"D (46 x 121.9 x 69cm)	198 lbs (90 kg)	8
DMXS-54H	120V, 1390W, 11.5 Amps	18 1/8"Hx54"Wx27 1/4"D (46 x 137.1 x 69cm)	208 lbs (94.5 kg)	9
DMXS-60H	120V, 1540W, 12.8 Amps	18 1/8"Hx60"Wx27 1/4"D (46 x 152.4 x 69cm)	226 lbs (102.7 kg)	10

Racer™ Horizontal Display Merchandiser—Double Shelf

	Electrical	Dimensions	Ship Wt.	Divider Rods
DMXD-30H	120V, 1340W, 11.5 Amps	27 1/2"H x30"W x27 1/4"D (70 x 76.2 x 69cm)	195 lbs (88.6 kg)	10
DMXD-36H	120V, 1640W, 14 Amps	27 1/2"H x36"W x27 1/4"D (70 x 91.4 x 69cm)	215 lbs (97.7 kg)	12
DMXD-42H	120V, 1915W, 16.5 Amps	27 1/2"H x42"W x27 1/4"D (70 x 106.6 x 69cm)	235 lbs (106.8 kg)	14
DMXD-48H	120V/208V, 2430W, 9.5 Amps 120V/240V, 2430W, 10 Amps	27 1/2"H x48"W x27 1/4"D (70 x 121.9 x 69cm)	260 lbs (118.2 kg)	16
DMXD-54H	120V/208V, 2705W, 13 Amps 120V/240V, 2705W, 11.3 Amps	27 1/2"H x54"W x27 1/4"D (70 x 137.1 x 69cm)	270 lbs (122.7 kg)	18
DMXD-60H	120V/208V, 3005W, 14.4 Amps 120V/240V, 3005W, 12.5 Amps	27 1/2"H x60"W x27 1/4"D (70 x 152.4 x 69cm)	280 lbs (127.3 kg)	20

PRODUCT SPECIFICATIONS

Construction:

RACER™ Horizontal Open Air Heated Merchandisers external top, back, sides and base are made of 20 gauge stainless steel. Heated shelves are made of Hard Coated Aluminum. Designer Front and back channels are made of powder coated aluminum extrusions. Overhead heat is backed with Mirror Polished Stainless Steel. 1/2" insulation surrounds each shelf base. Tempered glass end panels. 4" High Temperature Polycarbonate and steel legs. Stainless Steel divider rods.

Electrical Information:

RACER™ Horizontal Open Air Heated Merchandisers are equipped with at least a 72" power cord. All single shelf versions and double shelf versions up to 42" terminate with a 5-15P plug. Double shelf versions 48" and above terminate with a 14-20P plug. For these units, the lights are powered by a 120V circuit. Plugs exit out of the bottom of the equipment on the right hand side.

Display Area:

Height: 6 1/2" between each shelf

Depth of each Shelf: 22"

Length: All display areas are 6" less than the overall width of the designated unit (DMXD-42H has a 36" display area)

F.O.B. Cheyenne, WY

*APW Wyott reserves the right to modify specifications or discontinue models without incurring obligation.